

NOTE: 1
DESIGN CODE:
N/A

NOTE: 2
TECHNICAL CLASSIFICATION:
Article Type: 003-Valve Stabs
Main Group: 3.00. Misc-Valvestab
Intermediate Group: 3.40.9. Spares
Sub Group: 3.40.94.1. Stab

NOTE: 3
INTERFACE INFORMATION:
Pressure Rating Bar: N/A
Material: AISI 316L
Weight: 1,2 kg
Volume: 0,15 dm³
Surface Area: 352 cm²
Hydraulic: N/A
Mechanical: N/A
Electrical: N/A
Com. & Protocol: N/A

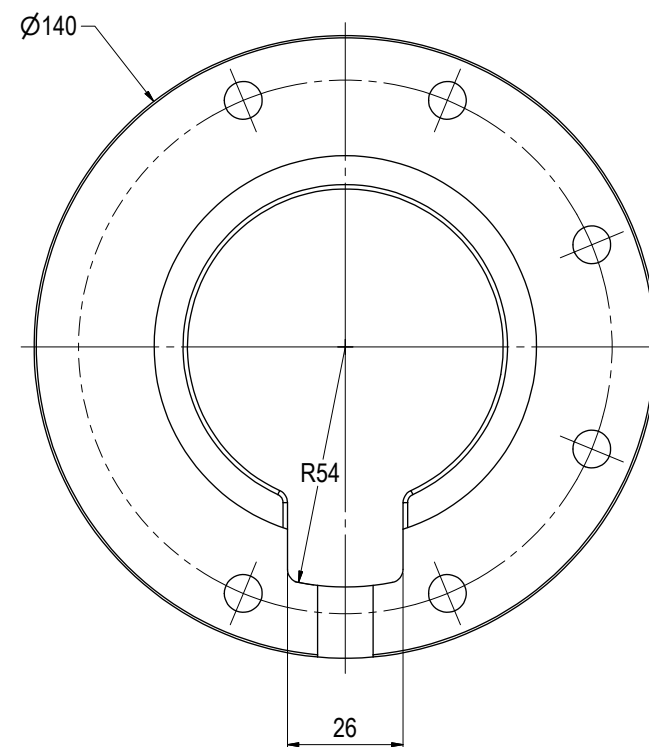
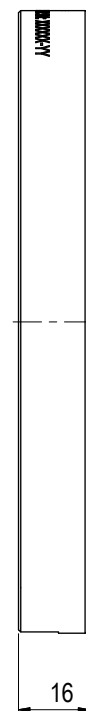
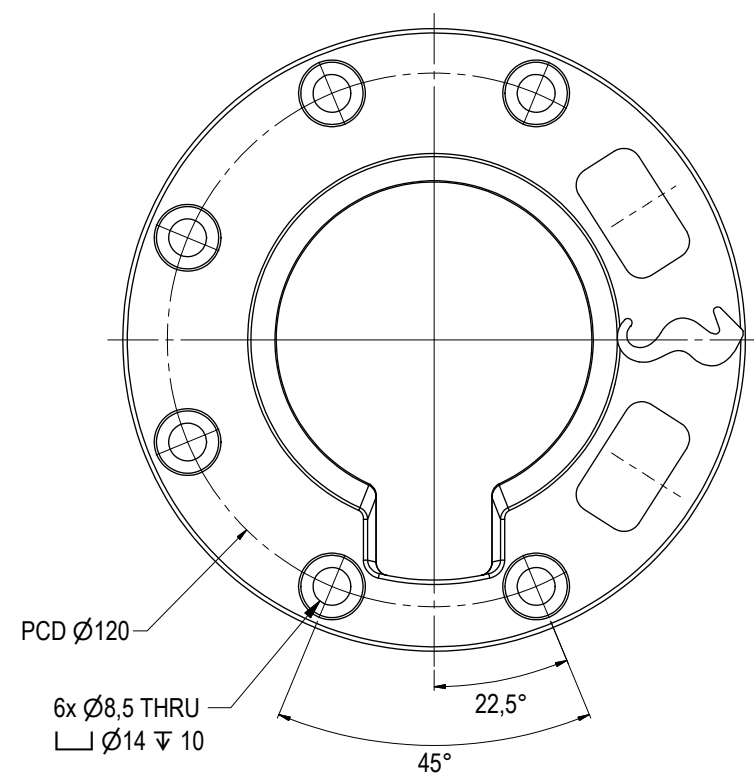

05	19.2.2018	7-IFC (Issued for Construction)		WTJ	LGH	WTJ
04	10.2.2016	7-IFC (Issued for Construction)		WTJ	HNJ	WTJ
03	28.10.2014	7-IFC (Issued for Construction)		HNJ	LGH	HNJ
02	5.10.2011	Issued for Construction		LGH	NA	NA
Rev.	Date	Reason for issue	Revision change	Made	Chk'd	Appr.



Unless Noted Otherwise:	Dwg Scale: NTS
Dim. Tol: NS-ISO 2768-1N/A	Dwg Proj:
Roughness: RaN/A	Dwg Format: A3
Fillet Rad: Corner Rmax: N/A	Break Edges: (R. Alt. 45°) R= 0,1-0,5

Drawing title: Top Plate Ø60 VStab Rec	Drawing number: BA1126	Rev: 05
--	------------------------	---------